

TOYOTA TECHNICAL SERVICE BULLETIN

REF.: BODY
NO.: BO95-012
DATE: NOVEMBER 24, 1995
MODEL: ALL MODELS

SEAT BELT EXTENDER (1987 TO 1996 MODEL YEARS)

Page 1 of 10

A special program is available for individuals who require extra length seat belts. Owners of 1987 through 1996 vehicles can now obtain seat belt extenders at no cost through their local Toyota dealer. (On vehicles from 1982 to 1986 – contact the Toyota Motor Sales (TMS) Customer Relations Department for availability.)

The extender is available in black only and in lengths of 6", 9", 12", 15" and 18".

Owners are informed of the seat belt extender availability through the Toyota Owner's Manual included in each 1987 or later vehicle (see page 9 for text of Owners Manual).

The owner must visit a Toyota Dealership to have the required measurements made and complete the seat belt extender worksheet. The worksheet will allow the proper fitting and selection of a seat belt extender for the customer. The dealer should then determine the part number needed and place a Critical Order for the item through the TDN Parts Network.

Attached are the following 1996 model year updated guides and examples:

- Flow Chart (Page 2)
- Seat Belt Extender Application/Part Number Chart (Pages 3 – 7)
- Owner Instruction Sheet (Page 8)
- Statement included in Owner's Manual (Page 9)
- Seat Belt Extender Worksheet (Page 10)

The dealership service department should complete the affixed Seat Belt Extender Label and review the "owner instruction sheet" with the owner. The dealer should give a copy of the completed worksheet to the owner and keep the original in the customer's file.

To assure utmost owner satisfaction, it is recommended that a dealer designate one person to coordinate all activities related to the seat belt extender issue.

Due to past sales history, it is recommended that dealers **DO NOT** stock seat belt extenders due to low demand for the parts and the need for custom fitting.

SEAT BELT EXTENDER (SBE) FLOW CHART:

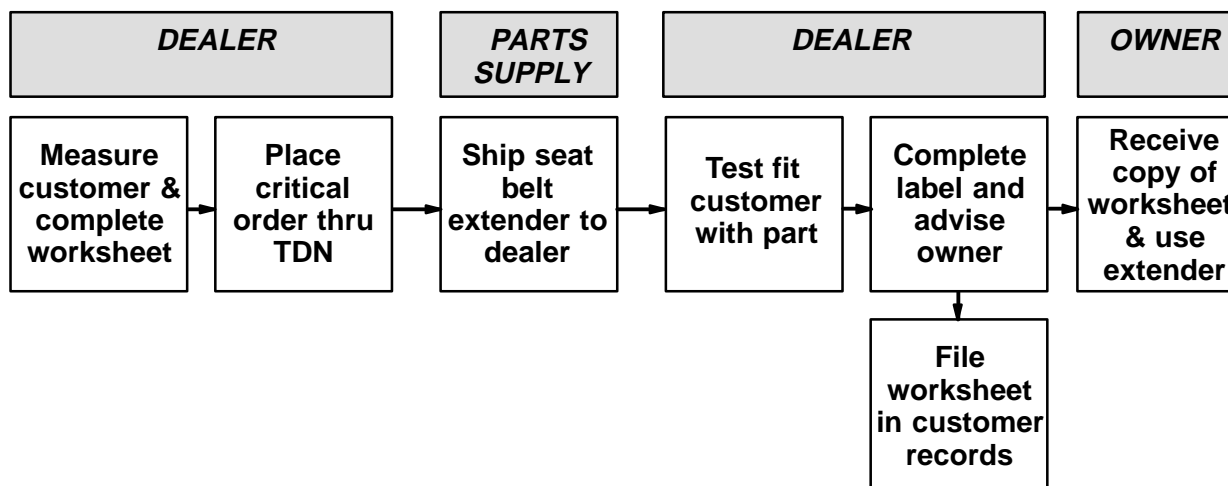

SEAT BELT LABEL SAMPLE

CAUTION			
THIS SEAT BELT EXTENDER IS TO BE USED ONLY BY: _____			
			Customer Name
ON VEHICLE: _____			
VIN: _____			
SEATING POSITION: _____			
Driver	Passenger	Front	Rear
USE BY OTHERS, OR IN ANOTHER SEATING POSITION, OR IN ANOTHER VEHICLE COULD REDUCE SEAT BELT RESTRAINT IN AN ACCIDENT AND RESULT IN PERSONAL INJURY.			

1. Owner requests a seat belt extender from the dealer.
2. Dealer verifies need for a seat belt extender and obtains current copy of TSB and copies the worksheet.
3. Dealer measures the customer and completes the worksheet. Dealer determines the correct part number needed and places a Critical Order for the part through the TDN Parts Network.
4. Dealer receives the seat belt extender and calls customer in to check fit of the part.
5. If the seat belt extender fit is OK, dealer completes the customer information label on the part, explains usage of the part and gives the customer a copy of the completed worksheet.
6. Dealer places a copy of the completed worksheet in the customer's records.

FRONT SEAT – EXTENDER APPLICATION TABLE

MODEL	TYPE	'96	'95	'94	'93	'92	'91	'90	'89	'88	'87
Cressida	USA Spec.					R-2*1	R-2*1	R-2*1	R-2*1	R-2	R-2
	Canada Spec.					K-3	K-3	K-3	K-3	K-3	K-3
Supra		R-3	R-3	R-3	R-3	R-1	R-1	R-1	R-1	R-1	R-1
Celica	L/B & Coupe	N-6	N-3	N-3	N-3	N-3	N-3	N-3	N-1	N-1	N-1
	Convertible	N-6	N-3		R-3	R-3	R-3	R-1	R-1	R-1	R-1
Camry	USA Spec.						R-2*1	R-2*1	R-2*1	R-2*1	R-2*1
	Canada Spec.						K-1	K-1	K-1	K-1	K-1
	TMC	R-3*2	R-3*2	R-3	R-3	R-3					
		Q-2*3	Q-2*3								
TMM	Q-2	Q-2	Q-2	Q-2	Q-2						
Corolla (2 dr)	Coupe						R-2*1	R-2*1	R-1	R-1	R-1
	Liftback										R-1
	FX									R-1	R-1
Corolla (4 dr)	Sedan	R-5*2	R-3*2	R-3*2	R-3	R-2*1	R-2*1	R-2*1	R-1	R-1	R-1
		Q-4*3	Q-2*3	Q-2*3							
	Wagon	R-5*2	R-3*2	R-3*2	R-3	R-2*1	R-2*1	R-2*1	R-1	R-1	
		Q-4*3	Q-2*3	Q-2*3							
	4wd Sedan					R-2*1	R-2*1	R-2*1	R-1		
	4wd Wagon				R-2*1	R-2*1	R-2*1	R-2*1	R-1	R-1	
	TMMC Prod.	Q-4	Q-2	Q-2	Q-2	R-2*1	R-2*1	R-2*1	R-1		
NUMMI Prod.	Q-4	Q-2	Q-2	Q-2	R-2*1	R-2*1	R-2*1	R-1			
Tercel	2,3 & 5 dr Sedan							R-2	R-1	R-2	R-2
	2 & 4 dr Sdn	RH	R-5	R-5	R-3*1	R-3*1	R-3*1	R-3*1			
		LH	R-5	R-3	R-3	R-3	R-3				
Wagon										R-1	R-1
Paseo		RH	R-5	R-3*1	R-3*1	R-3*1	R-3*1				
		LH	R-5	R-3	R-3	R-3	R-3*1				
Avalon		Q-2	Q-2								
MR2			R-3	R-3	R-3	R-3	R-3	R-1	R-1	R-1	R-1
Truck *4 (TMC)	Regular Cab		R-1*2	R-1	R-1	R-1	R-1	R-1	R-1	R-1	R-2
	Xtracab		Q-1*3								
Truck *4 (NUMMI)	Regular Cab		R-1	R-1	R-1						
	Xtracab		Q-1	Q-1	Q-1						

FRONT SEAT – EXTENDER APPLICATION TABLE CONT'D

MODEL	TYPE	'96	'95	'94	'93	'92	'91	'90	'89	'88	'87
T 100 *4		R-5	R-5	R-1	R-1						
4 Runner	2-dr				R-1	R-1	R-1	R-1	R-1	R-2	R-2
	4-dr	K-5	K-1	K-1	K-1	K-1	R-1	R-1	R-1		
Van/Previa		R-3	R-3	R-3	R-3	R-3	R-3	R-1	R-1	R-2	R-2
Land Cruiser	FJ60, FJ80	R-3	R-3	R-3	R-3	R-3	R-3	R-1*5	R-1	R-1	R-1
	FJ40, FJ70										K-1
Tacoma *4		Q-4	Q-4								
RAV4		R-5									

NOTES:

- *1 If dimension “L” is under 24 inches, the extender must not be used (see Figure 1 and 2). This applies to front lap seat belts equipped in the following models:
 - **Cressida** – '89, '90, '91, & '92 model years
 - **Camry** – '89, '90, & '91 model years
 - **Corolla** – on and after April, 1990 production, '91, & '92 model years
 - **Corolla 4WD Wagon** – '93 model only
 - **Tercel** – '91, '92, '93, '94 & '95 model years
 - **Paseo** – '92, '93, '94 & '95 model years
- *2 This seat belt was supplied by TOKAI RIKI. Make sure that the I/D mark on the back of the seat belt buckle is the same as shown in fig. 3.
- *3 This seat belt was supplied by QSS. Make sure that the I/D mark on the back of the seat belt buckle is the same as shown in fig. 4.
- *4 Extender must not be used for center seat belt on T100, Truck & Tacoma equipped with bench seat.
- *5 R-3 must be used for Land Cruiser (FJ80) produced on and after January, 1990.



Figure 3



Figure 4

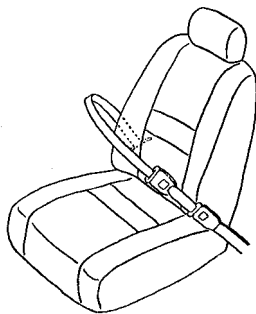

Figure 1

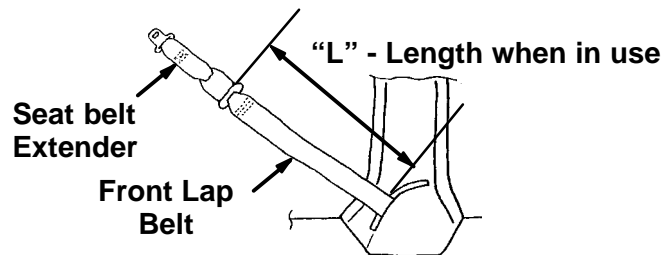

Figure 2

Note: The front lap belt for all '90 Corolla models and the '90 Tercel is the ALR type. Make sure the ALR is locked when the extender is used. **(Do not used if unlocked.)**

REAR SEAT – EXTENDER APPLICATION TABLE

MODEL	TYPE	'96	'95	'94	'93	'92	'91	'90	'89	'88	'87
Cressida	USA Spec.					K-2	K-2	K-2	K-2	K-1	K-1
Supra		R-3	R-3	R-3	R-3	N-4	N-4	N-1	N-1	N-2*5	N-2*5
Celica	L/B & Coupe	N-6	N-3	N-3	N-3	N-3	N-4	N-3	N-1	N-2	N-2
	Convertible	RH	N-1	N-1		N-1	N-1	N-1	N-3	N-1	N-2*5
LH		N-5	N-5		N-5	N-5	N-5				
Camry	TMC	R-3*2	R-3*2	R-3*2	R-3	R-4	R-1	R-1	R-1	R-2	R-2
		Q-2*3	Q-2*3	Q-2*3							
	TMM Sedan	Q-2	Q-2	Q-2	Q-2	Q-3	Q-1	Q-1	Q-1		
	Wagon (incl. 3rd seat)	Q-2	Q-2	Q-2	Q-2	Q-2	Q-1	Q-1	Q-1		
Coupe	Q-2	Q-2	Q-2								
Corolla (2 dr)	Coupe						K-1	K-1	K-1	K-1	K-1
	Liftback										K-1
	FX									A-1	A-1
Corolla (4 dr)	Sedan	R-5*2	R-3*2	R-3*2	R-3*2	R-1*1	R-1*1	R-1*1	R-1	R-2	R-1
		Q-4*3	Q-2*3	Q-2*3	Q-2*3						
	Wagon	R-5	R-3	R-3	R-3	R-1	R-1	R-1	R-1	R-1	
	4wd Sedan					R-1*1	R-1*1	R-1*1	R-1	R-1	
	4wd Wagon				N-1	N-1	N-1	N-1	N-1	N-1	N-2*5
	TMMC Produced	Q-4	Q-2*3	Q-2*3	Q-2*3	Q-1	Q-1	Q-1	Q-1	Q-1	
NUMMI Produced	A-2	A-2	A-2	A-2	A-1	A-1	A-1	A-1	A-1*		
Tercel	2,3 & 5 dr Sdn							R-1	R-1	R-1	R-1
	2 & 4 dr Sdn	R-5*2	R-5*2	R-3	R-3	R-4	R-4				
		Q-4*3	Q-4*3								
	Wagon						R-1	R-1	R-1	R-1	R-1
4wd Wgn									N-1	N-1	
Paseo		R-5	R-3	R-3	R-3	R-4					
Avalon		Q-2	Q-2								
Truck	Xtracab (TMC)		R-1	R-1	R-1	R-1	R-1	R-1	R-1	R-1	
Truck	Xtracab (NUMMI)		R-1	R-1	R-1						

REAR SEAT – EXTENDER APPLICATION TABLE (CONT'D)

MODEL	TYPE	'96	'95	'94	'93	'92	'91	'90	'89	'88	'87
T100*4		K-4	K-4								
4Runner	2 & 4 dr	R-5	R-1	R-1	R-1	R-1	R-1	R-1	R-1	K-1	K-1
Van/Previa	(Incl. 3rd seat)	R-3	R-3	R-3	R-3	R-3	R-3	R-1	R-1	R-1	R-1
Land Cruiser	(Incl. 3rd seat)	K-4	R-4	K-4	K-4	K-2	K-2	K-1*4	K-1	K-1	K-1
Tacoma	Xtracab	K-3	K-3								
RAV4		R-5*2 Q-4*3									

NOTES:

- * For September and October, 1988 NUMMI Corolla production, the extender “R-1” must be used, not “A-1”.
- *1 For TMC production Corolla Sedan (on and after April, 1990 production, '91, & '92 models), if dimension “L2” & “L1” is under 13 inches (see figure 3), the extender **must not** be used.
- *2 This seat belt was supplied by TOKAI RIKA. Make sure that the I/D mark on the back of the seat belt buckle is the same as shown in fig. 4.
- *3 This seat belt was supplied by QSS. Make sure that the I/D mark on the back of the seat belt buckle is the same as shown in fig. 5.
- *4 For Land Cruiser (FJ80) production after January, 1990, extender “K-2” must be used.
- *5 If a vehicle is equipped with a rear 3-point seat belt, the extender “N-1” must be used, not “N-2”.

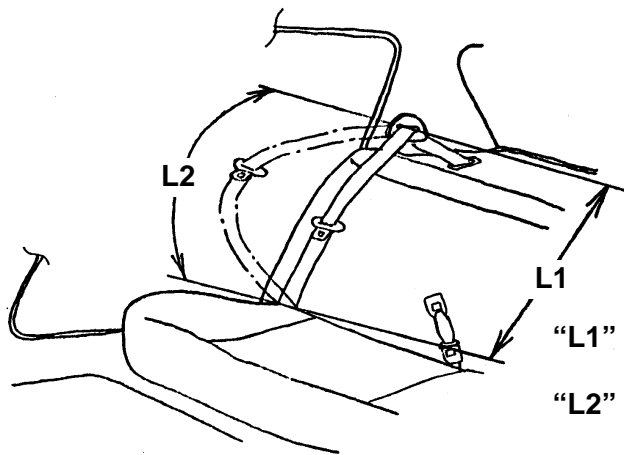

Figure 3



Figure 4



Figure 5

“L1” – Retracted Length

“L2” – Length when in use (extender attached)

Note: The extender **must not be used** for the center rear seat belt on any model.

PART NUMBER INFORMATION:

(73399-_____)

Series	Length				
	6"	9"	12"	15"	18"
R-1	-12010	-12020	-12030	-12040	-12050
R-2	-12160	-12170	-12180	-12190	-12200
R-3	-50010	-50020	-50030	-50040	-50050
R-4	-16010	-16020	-16030	-16040	-16050
R-5	-16060	-16070	-16080	-16090	-16100
N-1	-12060	-12070	-12080	-12090	-12100
N-2	-12210	-12220	-12230	-12240	-12250
N-3	-20011	-20021	-20031	-20041	-20051
N-4	-20060	-20070	-20080	-20090	-20100
N-5	-20110	-20120	-20130	-20140	-20150
N-6	-20160	-20170	-20180	-20190	-20200
K-1	-12110	-12120	-12130	-12140	-12150
K-2	-22010	-22020	-22030	-22040	-22050
K-3	-22060	-22070	-22080	-22090	-22100
K-4	-33010	-33020	-33030	-33040	-33050
K-5	-35010	-35020	-35030	-35040	-35050
A-1	-02010	-02020	-02030	-02040	-02050
A-2	-01060* ¹	-01070	-01080	-01090	-01100
Q-1	-02060	-02070	-02080	-02090	-02100
Q-2	-06010	-06020	-06030	-06040	-06050
Q-3	-06060	-06070	-06080	-06090	-06100
Q-4	-0W010	-0W020	-0W030	-0W040	-0W050

*1 Length: 7¹/₄"

OWNER INSTRUCTION:

Failure to follow the recommendations indicated below could result in less effectiveness of the seat belt restraint system in case of vehicle collision, causing personal injury.

1. The seat belt extender must not be used:
 - (I) By anyone other than for whom it was provided (name recorded on seat belt extender).
 - (II) In any vehicle or seat position other than the one for which it is provided.
2. To connect the extender to the seat belt, insert the tab into the seat belt buckle so that the buckle–release buttons of the extender and the seat belt are located on the same side as shown. You will hear a click when the tab locks into the buckle. Make sure that the connection is secure and the seat belt extender is not twisted.
3. When the seat belt extender is provided for rear seat position (with automatic locking retractor), make sure the retractor is locked when in use.
4. When releasing the seat belt, press on the buckle–release button on the extender, not on the seat belt. This helps prevent damage to the vehicle interior and extender itself.

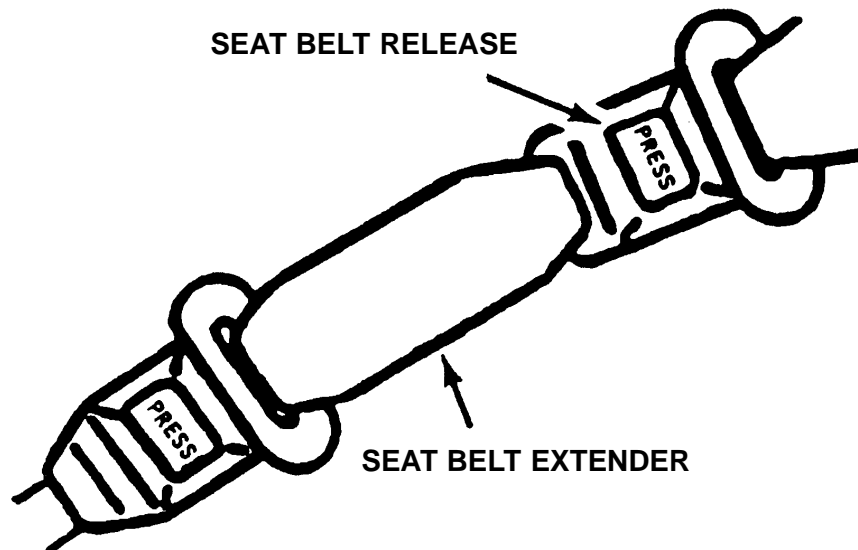

5. When not in use, remove the extender and store in the vehicle for future use.

OWNER'S MANUAL TEXT:**Seat belt extender**

If your seat belt cannot be fastened securely because it is not long enough, a personalized seat belt extender is available from your Toyota dealer free of charge.

Please contact your local Toyota dealer so that the dealer can order the proper required length for the extender. Bring the heaviest coat you expect to wear for proper measurement and selection of length. Additional ordering information is available at your Toyota dealer.

CAUTION:

When using the seat belt extender, observe the following. Failure to follow these instructions could result in less effectiveness of the seat belt restraint system in case of vehicle accident, increasing the chance of personal injury.

- **Never use the seat belt extender if you can fasten the seat belt without it.**
- **Remember that the extender provided for you may not be safe when used on a different vehicle, or for another person and at different seating positions than the one originally intended for.**

To connect the extender to the seat belt, insert the tab into the seat belt buckle so that the "PRESS" signs on the buckle-release buttons of the extender and the seat belt are both facing outward as shown.

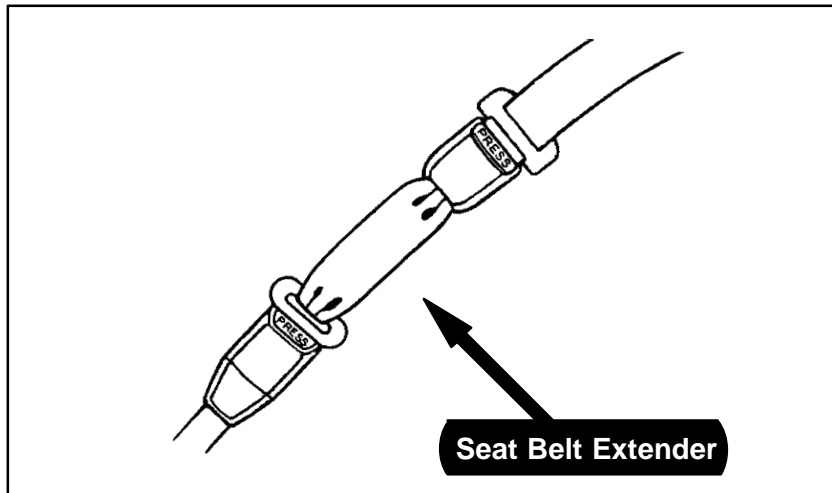

You will hear a click when the tab locks into the buckle.

When releasing the seat belt, press on the buckle-release button on the extender, not on the seat belt. This helps prevent damage to the vehicle interior and extender itself.

When not in use, remove the extender and store in the vehicle for future use.



SEAT BELT EXTENDER WORKSHEET

Please copy this original worksheet for each extender needed.

CAUTION: To minimize the chance and/or severity of injury in an accident, the seat belt extender must not be used:

- By anyone but the person for whom it was provided, and
- In any vehicle or seat specified other than the one for which it was provided, and
- With any car child safety seats.

When the seat belt extender is provided for rear seat positions (with automatic locking retractor), make sure the retractor is locked when in use.

In all cases seat belts must be worn below the abdomen by pregnant women.

DEALER		PLEASE PRINT CLEARLY			APPLICANT	
DEALER CODE	DEALER NAME	APPLICANT NAME				
ADDRESS			ADDRESS			
CITY AND STATE		ZIP CODE	CITY AND STATE		ZIP CODE	TELEPHONE
DEALER EMPLOYEE NAME	MODEL YEAR	BODY TYPE	SEAT POSITION F / R	VEHICLE IDENTIFICATION NUMBER		

DIRECTIONS FOR DETERMINING PROPER EXTENDER LENGTH

1. Place the seat in the position the person normally uses.
2. With the person in the seat, extend the seat belt as much as possible and see if the belt latches.
3. If the buckle latches but has no slack remaining, the dimension for Figure 2 is zero. If the seat belt does not latch, measure the distance from the seat belt latch edge to the seat belt buckle as shown in Figure 2 below, and note the dimension.
4. Measure the lap area directly below the navel to the edge of the buckle as shown in Figure 1 and note the dimension.
5. The difference between Figure 1 and Figure 2 measurements is the "Allowable Margin". (Do not use this dimension for the extender length.)
6. Take the measurement in Figure 2 and round it up to the next extender size available, without exceeding the "Allowable Margin".

FIGURE 1
DIMENSION FROM NAVAL TO BUCKLE

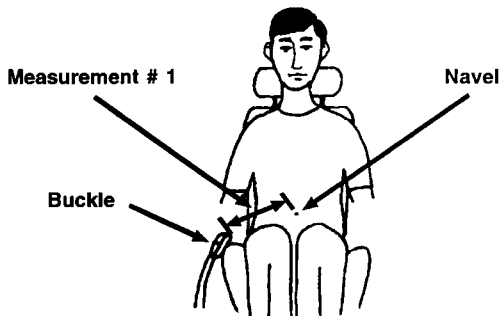
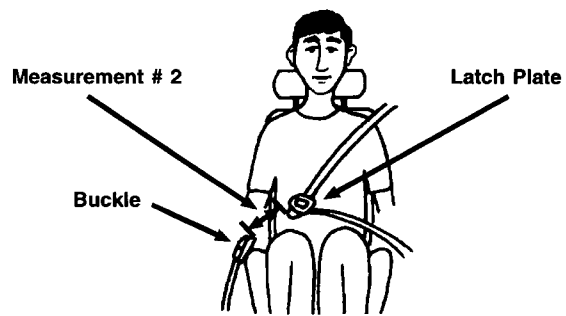

FIGURE 2
DIMENSION FROM LATCH TO BUCKLE



Measurement #1 (Figure 1) - Measurement #2 (Figure 2) = "Allowable Margin"

_____ - _____ = _____

NOTE: The length of the extender must not exceed the "Allowable Margin", due to design and construction features

AUTHORIZATION

The same extender can be used for right and left seating applications. Each seat belt extender will be affixed with a label identifying the owner, vehicle VIN and seating position. Extenders are available in one color only.

APPLICANT'S SIGNATURE
(Actual user of seat belt extender)

DATE